

**Ersatzteilliste**  
**Spare parts list**  
**Liste de pièces détachées**



**Geschirr- und Gläserpülautomat**  
**Dish- and glasswashing machines**  
**Machine à laver la vaisselle et verres**

**EcoStar 530 F-M**

**FA**





**PLATON**SERVICE

8 (800) 500-34-47

[www.platonservice.com](http://www.platonservice.com)

# EcoStar 530 F-M FA

<b>Inhaltsverzeichnis:</b>	<b>Contents:</b>	<b>Contenu:</b>	<b>Seite/ Page</b>
01.34 Waschpumpe	Wash pump	Pompe de lavage	4
02.12 Pumpenansaugung	Pump suctioning	Aspiration de pompe	6
03.35 Wasch- und Nachspülsystem	Washing and rinsing system	Système de lavage et rinçage	8
04.32 Magnetventil	Solenoid valve	Electrovanne	10
06.09 Niveauregelung	Level control	Régulation de niveau	11
08.36 Einbauboiler	Incorporated boiler	Surchauffeur incorporé	12
09.24 Tankheizung	Tank heating	Chauffage de bac	15
10.18 Dosiergeräte	Dosing units	Doseurs	16
11.73 Elektroniksteuerung	Electronic control	Commande électronique	18
13.48 Baugruppen/Einzelteile	Component blocks/Parts	Blocs/Pièces détachées	20
18.22 Laugenpumpe	Drain pump	Pompe de vidange	21
22.27 Drucksteigerungspumpe	Booster pump	Surpresseur	22
24.07 Freier Auslauf	Air gap	Ecoulement libre	24
25.02 Türgewichtsausgleich	Door counterweight	Equilibrage de poids de porte	25



## **KENNEICHNUNG DER ER-SATZTEILE**

\* / V DIESE TEILE EMPFEHLEN WIR AUF LAGER ZU LEGEN!

V VERSCHLEISSTEIL!

ÄNDERUNGEN IN AUSFÜHRUNG UND KONSTRUKTION VORBEHALTEN.

## **SPECIAL MARKS OF SPARES**

WE RECOMMEND TO STORE THESE PARTS!

WEAR AND TARE PART!

WE RESERVE THE RIGHT TO CHANGE EXECUTION AND CONSTRUCTION.

## **MARQUAGE SPECIALES DES PIECES**

NOUS RECOMMANDONS DE PRENDRE CES PIECES EN STOCK!

PIÈCE D'USURE!

NOUS NOUS RESERVONS LE DROIT DE CHANGER L'EXECUTION ET LA CONSTRUCTION.

MEIKO Maschinenbau GmbH & Co. KG

Englerstraße 3

D-77652 Offenburg

Telefon: 0781 / 203 - 0

Telefax: 0781 / 203 - 1274

www.meiko.de

e-mail: [info@meiko.de](mailto:info@meiko.de)

**01.34 WASCHPUMPE**

**01.34 WASH PUMP**

**01.34 POMPE DE LAVAGE**



PU1\_34\_.doc  
22.03.2006/BP



## 01.34 WASCHPUMPE

## 01.34 WASH PUMP

## 01.34 POMPE DE LAVAGE



PU1\_34,.doc  
22.03.2006/BP

POS	IDENT. NR. IDENT. NO.	BEZEICHNUNG	DESIGNATION	DESIGNATION
1	* 9623861	WASCHPUMPE 0,55 KW KPL.	WASH PUMP 0,55 KW CPL.	POMPE DE LAVAGE 0,55 KW CPL.
2	V 0501095	GLEITRINGDICHTUNG KPL.	SLIDING SEAL CPL.	JOINT AXIAL
3	* 9500310	PUMPENGEHÄUSEDICHTUNG	PACKING FOR PUMP HOUSING	JOINT POUR CORPS DE POMPE
4	* 0501137	PUMPENLAUFRAD	PUMP WHEEL	ROUE DE POMPE
5	9500311	PUMPENGEHÄUSE	PUMP HOUSING	CORPS DE POMPE
6	9624002	FEDERBANDSCHELLE Ø55	HOSE CLAMP TAPE Ø55	RUBAN COLLIER DE SERRAGE Ø55
7	9625072	SCHLAUCHVERBINDUNG	HOSE COUPLING	RACCORD POUR TUYAUX
8	9624003	FEDERBANDSCHELLE Ø50	HOSE CLAMP TAPE Ø50	RUBAN COLLIER DE SERRAGE Ø50
9	9627394	FEDERBANDSCHELLE Ø11,5	HOSE CLAMP TAPE Ø11,5	RUBAN COLLIER DE SERRAGE Ø11,5
10	9628185	ROHR Ø6	TUBE Ø6	TUYAU Ø6
11	9601265	SCHLAUCHHALTER	HOSE BRACKET	SUPPORT DE TUYAU
12	0640007	SCHLAUCH SCHWARZ Ø40 X 5	HOSE BLACK Ø40 X 5	TUYAU FLEXIBLE NOIR Ø40 X 5
13	9544641	SANFTANLAUFVENTIL 24V	SMOOTH START VALVE 24V	VALVE POUR DEMARRAGE EN DOUCEUR 24V
14	9500045	SCHLAUCHKLEMME GELB	HOSE WIRE CLAMP YELLOW	COLLIER DE SERRAGE JAUNE
15	0260007	SCHLAUCH KLARSICHT Ø6	HOSE TRANSPARENT Ø6	TUYAU TRANSPARENT Ø6
16	0501090	KONDENSATOR 12µF	CONDENSER 12µF	CONDENSEUR 12µF



8 (800) 500-3444  
www.platonservice.com

## 02.12 PUMPENANSAUGUNG

## 02.12 PUMP SUCTIONING

## 02.12 ASPIRATION DE POMPE



PA02\_12.doc  
16.03.06/BP



## 02.12 PUMPENANSAUGUNG

## 02.12 PUMP SUCTIONING

## 02.12 ASPIRATION DE POMPE



PA02\_12.doc  
16.03.06/BP

POS	IDENT. NR. IDENT. NO.	BEZEICHNUNG	DESIGNATION	DESIGNATION
1	0620347	STANDROHR, 140 LANG	STAND PIPE, 140 LONG	BONDE DE TROP-PLEIN, 140 LONG
2	0620346	SIEB MIT SCHMUTZRINNE K 337	FILTER WITH DIRT TRAP K 337	TAMIS AVEC PROFILE A DECHETS K 337
3	9630597	SIEB	SIEVE	TAMIS
4	* 0401061	O-RING 206,5 X 3,53	O-RING 206,5 X 3,53	BAGUE O 206,5 X 3,53
5	9625059	PUMPENSUMPF	PUMP SUMP	CUVETTE DE POMPE
6	9624003	FEDERBANDSCHELLE Ø50	HOSE CLAMP TAPE Ø50	RUBAN COLLIER DE SERRAGE Ø50
7	9625217	SCHLAUCHVERBINDUNG	HOSE COUPLING	RACCORD POUR TUYAUX
8	9607417	FEDERBANDSCHELLE Ø30	HOSE CLAMP TAPE Ø30	RUBAN COLLIER DE SERRAGE Ø30



PLATON SERVICE  
8 (800) 500-34-41  
www.platonservice.com

### 03.35 WASCH- UND NACHSPÜLSYSTEM

### 03.35 WASHING AND RINSING SYSTEM

### 03.35 SYSTEME DE LAVAGE ET RINCAGE



Wn3\_35.doc  
27.04.2006/BP

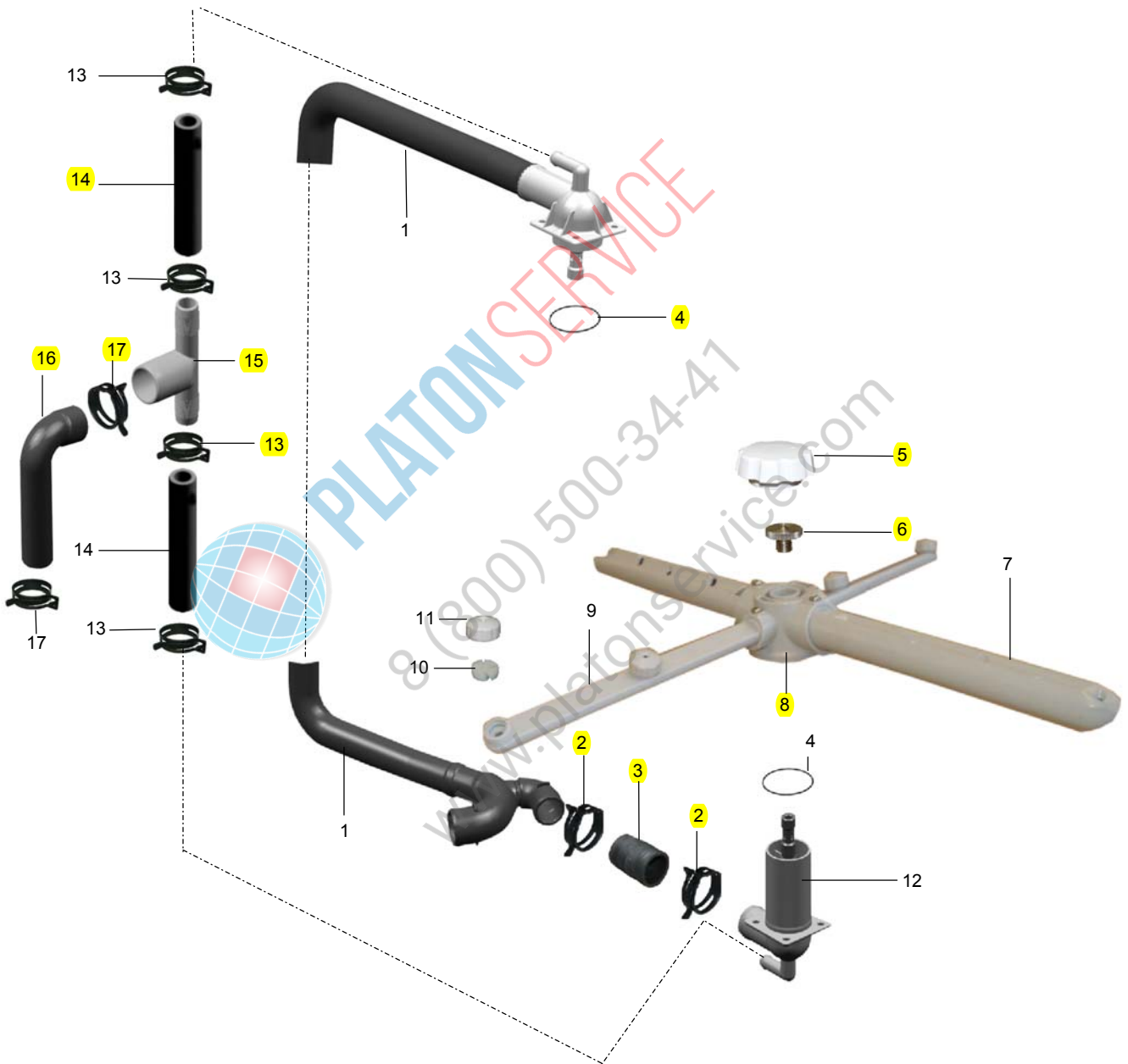



## 03.35 WASCH- UND NACHSPÜLSYSTEM

## 03.35 WASHING AND RINSING SYSTEM

## 03.35 SYSTEME DE LAVAGE ET RINCAGE



POS	IDENT. NR. IDENT. NO.	BEZEICHNUNG	DESIGNATION	DESIGNATION
1	* 9630498	STEIGLEITUNG MIT DREHARMLAGER OBEN	ASCENDING PIPE WITH WASH ARM PIVOT TOP	CONDUITE ASCENDANTE AVEC AVEC PIVOT BRAS ROTATIFS HAUT
2	9624004	FEDERBANDSCHELLE Ø43	HOSE CLAMP TAPE Ø43	RUBAN COLLIER DE SERRAGE Ø43
3	0640048	SCHLAUCH	HOSE	TUYAU FLEXIBLE
4	0401030	O-RING 50 X 1,5	O-RING 50 X 1,5	BAGUE O, 50 X 1,5
5	0620384	SCHRAUBKAPPE	SCREW CAP	CAPUCHON VISSE
6	0310010	RÄNDELSCHRAUBE	KNURLED SCREW	VIS MOLETEE
7	0620385	WASCHARM 1, LANG SCHLITZ INNEN SCHRÄG	WASH ARM 1, LONG SLIT INTERIOR OBLIQUE	BRAS DE LAVAGE 1, LONG FENTE INTERIEURE OBLIQUE
	0620386	WASCHARM 2, LANG SCHLITZ INNEN GERADE	WASH ARM 2, LONG SLIT INTERIOR STRAIGHT	BRAS DE LAVAGE 2, LONG FENTE INTERIEURE DROITE
8	0620380	DREHARMNABE	UPPER ROTATING ARM	MOYEU DE BRAS ROTATIF
9	0620389	NACHSPÜLARM 1, LANG	FINAL RINSE ARM 1, LONG	BRAS DE RINCAGE FINAL 1, LONG
	0620390	NACHSPÜLARM 2, MITTEL	FINAL RINSE ARM 2, MEDIUM	BRAS DE RINCAGE FINAL 2, ME- DIUM
10	0620121	DRALLEINSATZ	TWISTING FLAT	AILETTE
11	0620157	NACHSPÜLDÜSENKAPPE	CAP FOR RINSE NOZZLE	CAPUCHON POUR GICLEUR DE RINCAGE
12	9623994	DREHARMLAGER UNTEN	WASH ARM PIVOT BOTTOM	PIVOT BRAS ROTATIFS BAS
13	9607418	FEDERBANDSCHELLE Ø21	HOSE CLAMP TAPE Ø21	RUBAN COLLIER DE SERRAGE Ø21
14	* 9608600	SCHLAUCH ½"	HOSE ½"	TUYAU ½"
15	9601255	T-STÜCK	T-PIECE	PIECE EN T
16	9622355	SCHLAUCHVERBINDUNG	HOSE COUPLING	RACCORD POUR TUYAUX
17	9607417	FEDERBANDSCHELLE Ø30	HOSE CLAMP TAPE Ø30	RUBAN COLLIER DE SERRAGE Ø30

## 04.32 MAGNETVENTIL

## 04.32 SOLENOID VALVE

## 04.32 ELECTROVANNE



MV4\_32.doc  
27.04.2006/BP

Optional für Niederlande / optional for Netherlands / option pour les pays-bas



POS	IDENT. NR. IDENT. NO.	BEZEICHNUNG	DESIGNATION	DESIGNATION
1	0113098	MAGNETVENTILFILTERSIEB	FILTER SIEVE F. SOLENOID VALVE	TAMIS-FILTRE P. ELECTROVANNE
2	9511458	MENGENREGLER 5 L/ MIN.	QUANTITY REGULATOR 5 L/MIN	REGULATEUR DE QUANTITE 5 L/MIN
3	* 9623108	MAGNETVENTIL PN 10 24V GERA- DE AUSFÜHRUNG	SOLENOID VALVE PN 10 24V LINEAR EXECUTION	ELECTROVANNE NW 10 24V EXECUTION LINEAIRE
4	* 9609462	FEDERBANDSCHELLE Ø17	HOSE CLAMP TAPE Ø17	RUBAN COLLIER DE SERRAGE Ø17
5	* 9608607	SCHLAUCH 3/8"	HOSE 3/8"	TUYAU 3/8"
	* 9541795	SCHLAUCH 3/8" WRC-ZULASSUNG	HOSE 3/8" WRC APPROVAL	TUYAU 3/8" APPROBATION WRC
		<b>OPTIONAL FÜR NIEDERLANDE</b>	<b>OPTIONAL FOR NETHERLANDS</b>	<b>OPTION POUR LES PAYS-BAS</b>
6	9500454	RÜCKSCHLAGVENTIL 3/4" A X 3/4" I	CHECK VALVE 3/4" A X 3/4" I	CLAPET ANTI-RETOUR 3/4" A X 3/4" I

## 06.09 NIVEAUREGELUNG

## 06.09 LEVEL CONTROL

## 06.09 REGULATION DE NIVEAU



Nvr6\_9.doc  
21.03.2006/BP

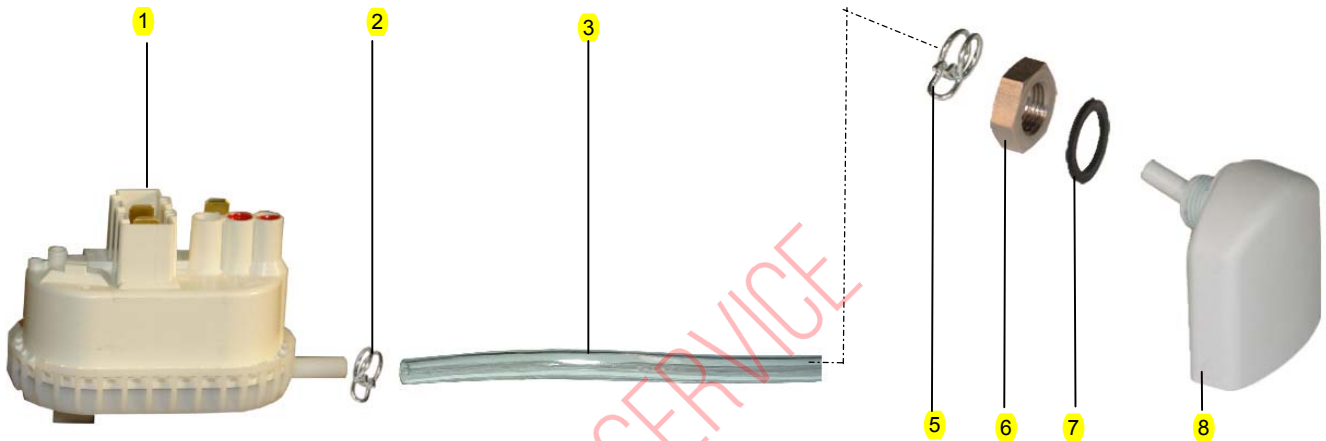

PLATON SERVICE  
8 (800) 500-34-41  
www.platonservice.com

POS	IDENT. NR. IDENT. NO.	BEZEICHNUNG	DESIGNATION	DESIGNATION
1	* 9622397	NIVEAUSCHALTER 40/15	LEVEL SWITCH 40/15	INTERRUPTEUR DE NIVEAU 40/15
2	* 9500044	SCHLAUCHKLEMME SILBER	HOSE WIRE CLAMP SILVER	COLLIER DE SERRAGE ARGENT
3	* 0260006	SCHLAUCH KLARSICHT Ø5	HOSE TRANSPARENT Ø5	TUYAU TRANSPARENT Ø5
4	9601265	SCHLAUCHHALTER	HOSE BRACKET	SUPPORT DE TUYAU
5	* 9500045	SCHLAUCHKLEMME GELB	HOSE WIRE CLAMP YELLOW	COLLIER DE SERRAGE JAUNE
6	9515957	MUTTER 3/8"	NUT 3/8"	ECROU 3/8"
7	* 9515964	DICHTUNG	PACKING	JOINT
8	* 9515955	LUFTFALLE	AIR TRAP	CHAMBRE DE COMPRESSION

**08.36 EINBAUBOILER**

**08.36 INCORPORATED BOILER**

**08.36 SURCHAUFFEUR INCORPORE**



BH8\_36.doc  
01.12.2002/FUS

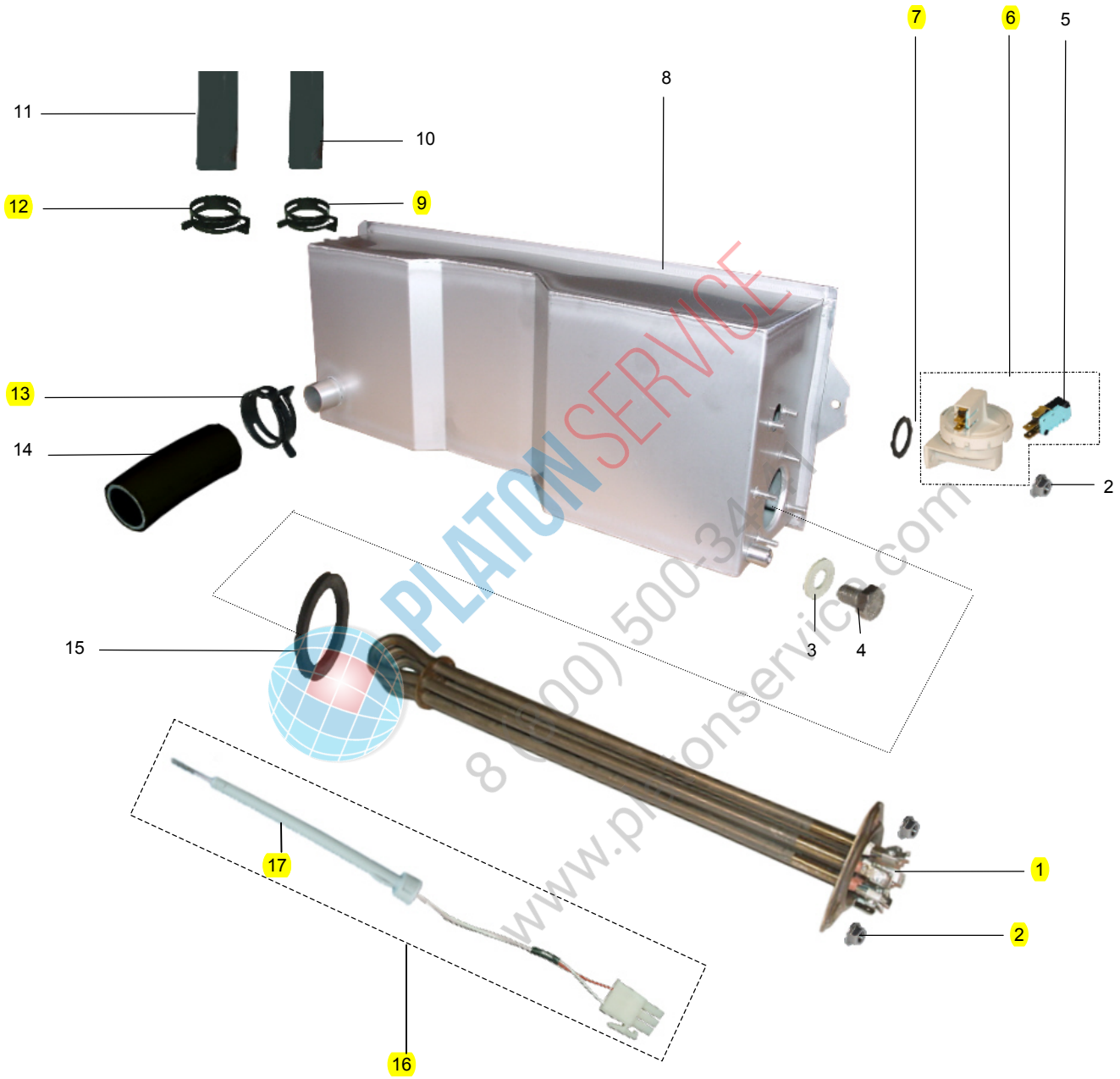

## 08.36 EINBAUBOILER

## 08.36 INCORPORATED BOILER

## 08.36 SURCHAUFFEUR INCORPORE



BH8\_36.doc  
01.12.2002/FUS

POS	IDENT. NR. IDENT. NO.	BEZEICHNUNG	DESIGNATION	DESIGNATION
1	* 9519586	HEIZKÖRPER 3KW MIT THERMO-SICHERUNG	HEATING ELEMENT 3 KW WITH THERMAL PROTECTION	RESISTANCE 3 KW AVEC PROTECTION THERMIQUE
	* 9519587	HEIZKÖRPER 4,5KW MIT THERMOSICHERUNG	HEATING ELEMENT 4,5 KW WITH THERMAL PROTECTION	RESISTANCE 4,5 KW AVEC PROTECTION THERMIQUE
	* 9519588	HEIZKÖRPER 6KW MIT THERMO-SICHERUNG	HEATING ELEMENT 6 KW WITH THERMAL PROTECTION	RESISTANCE 6 KW AVEC PROTECTION THERMIQUE
	* 9519590	HEIZKÖRPER 7,5KW MIT THERMOSICHERUNG	HEATING ELEMENT 7,5 KW WITH THERMAL PROTECTION	RESISTANCE 7,5 KW AVEC PROTECTION THERMIQUE
2	0335008	MUTTER M5	NUT M5	ECROU M5
3	9522687	DICHTUNG	PACKING	JOINT
4	0302006	SCHRAUBE M8X15	SCREW M8X15	VIS M8X15
5	* 0122103	MIKROSCHALTER	SWITCH	INTERRUPTEUR
6	* 9622898	NIVEAUSCHALTER KPL	LEVEL SWITCH CPL	INTERRUPTEUR DE NIVEAU CPL
7	* 0401014	O-RING 18X2	O-RING 18X2	BAGUE 18X2
8	9603367	EINBAUBOILERGEHÄUSE KPL	BOILER HOUSING CPL	BOITE DE SURCHAUFFEUR CPL
9	9609462	FEDERBANDSCHELLE Ø17	HOSE CLAMP TAPE Ø17	RUBAN COLLIER DE SERRAGE Ø17
10	9607596	SCHLAUCH 3/8"	HOSE 3/8"	TUYAU 3/8"
11	9607590	SCHLAUCH 1/2"	HOSE 1/2"	TUYAU 1/2"
12	9607418	FEDERBANDSCHELLE Ø21	HOSE CLAMP TAPE Ø21	RUBAN COLLIER DE SERRAGE Ø21
13	9607416	FEDERBANDSCHELLE Ø36	HOSE CLAMP TAPE Ø36	RUBAN COLLIER DE SERRAGE Ø36
14	9005525	SCHLAUCH 28 X 4 - 55	HOSE 28 X 4 - 55	TUYAU 28 X 4 - 55
	900618	SCHLAUCH 28 X 4 - 100 FÜR ECOSTAR 530F-M FA	HOSE 28 X 4 - 100 FOR ECOSTAR 530F-M FA	TUYAU 28 X 4 - 100 POUR ECOSTAR 530F-M FA
15	* 0101176	HEIZKÖRPERDICHTUNG	HEATING ELEMENT PACKING	JOINT DE RESISTANCE
		<b>GÜLTIG BIS 2005-03</b>	<b>VALID UNTIL 2005-03</b>	<b>VALABLE JUSQU'AU 2005-03</b>
	9545533	TEMPERATURFÜHLER 3M	TEMPERATURE PROBE 3M	SONDE DE TEMPERATURE 3M
	9611295	KABELSCHELLE	CABLE CLIP	COLLIER DE CABLE
		<b>GÜLTIG AB 2005-04</b>	<b>VALID FROM 2005-04</b>	<b>VALABLE A PARTIR DU 2005-04</b>
16	9614768	TEMPERATURFÜHLER MONTAGEBAUGRUPPE.	TEMPERATURE PROBE ASSEMBLY	SONDE DE TEMPERATURE JEU DE MONTAGE
17	9611295	KABELSCHELLE	CABLE CLIP	COLLIER DE CABLE



**PLATON**SERVICE

8 (800) 500-34-47

[www.platonservice.com](http://www.platonservice.com)

## 09.24 TANKHEIZUNG

## 09.24 TANK HEATING

## 09.24 CHAUFFAGE DE BAC



TH9\_24.doc  
20.03.2006/BP

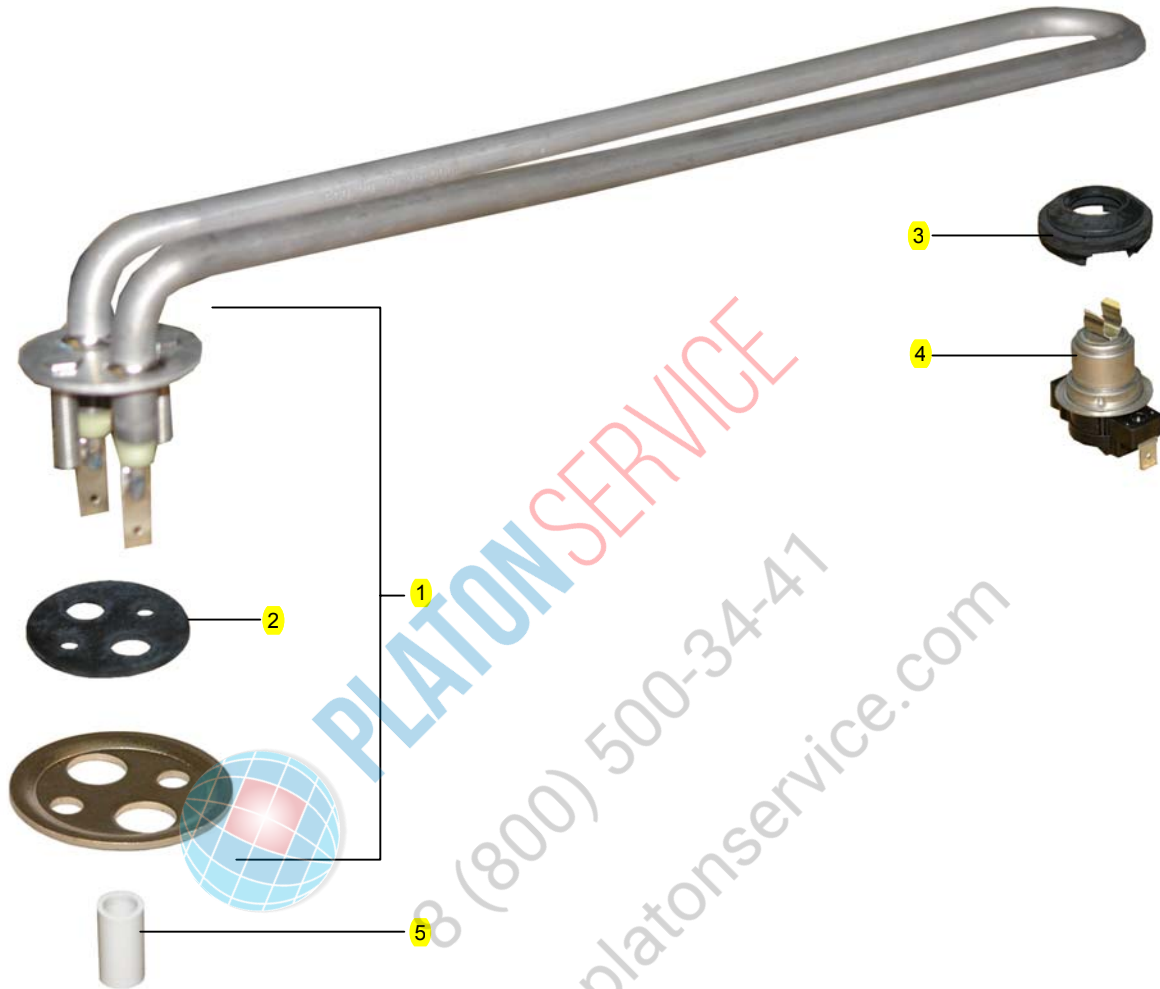

POS	IDENT. NR. IDENT. NO.	BEZEICHUNG	DESIGNATION	DESIGNATION
1	* 0101152	HEIZKÖRPER 2 KW, 230 V	HEATING ELEMENT 2 KW, 230 V	RESISTANCE 2 KW, 230 V
2	* 0101175	HEIZKÖRPERDICHTUNG	HEATING ELEMENT PACKING	JOINT DE RESISTANCE
3	* 0108040	GUMMIMANSCHETTE	RUBBER PACKING	MANCHETTE EN CAOUTCHOUC
4	* 0108043	TEMPERATURBEGRENZER	TEMPERATURE LIMITER	LIMITEUR DE TEMPERATURE
5	9543319	BERÜHRUNGSSCHUTZ	PROTECTION AGAINST CONTACT	PROTECTION CONTRE CONTACT

# 10.18 DOSIERGERÄTE

# 10.18 DOSING UNITS

# 10.18 DOSEURS



DOS10\_18.doc  
22.03.2006/BP





## 10.18 DOSIERGERÄTE

## 10.18 DOSING UNITS

## 10.18 DOSEURS



DOS10\_18.doc  
22.03.2006/BP

POS	IDENT. NR. IDENT. NO.	BEZEICHNUNG	DESIGNATION	DESIGNATION
1	9544292	REINIGERDOSIERPUMPE KPL	DETERGENT DOSING PUMP CPL.	POMPE DE DOSAGE DETERGENT CPL.
2	V 9511675	SCHLAUCH REINIGER KPL	HOSE DETERGENT CPL.	TUYAU DETERGENT CPL.
3	* 9500045	SCHLAUCHKLEMME GELB	HOSE WIRE CLAMP YELLOW	COLLIER DE SERRAGE JAUNE
4	* 0260007	SCHLAUCH KLARSICHT Ø6	HOSE TRANSPARENT Ø6	TUYAU TRANSPARENT Ø6
5	8000013	SCHLAUCHANSCHLUß	HOSE CONNECTION	CONNEXION DE TUYAU FLEXIBLE
6	* 9603787	FLACHDICHTUNG 10X16X2	FLAT PACKING 10X16X2	GARNITURE PLATE 10X16X2
7	9603790	FEDERSCHEIBE M10	SPRING WASHERV M10	RONDELLE ÉLASTIQUE M10
8	0335019	SECHSKANTMUTTER	HEXAGON NUT	ECROU A SIX PANS
9	8005372	ANSAUGROHR, 420 MM	SUCTION TUBE, 420 MM	CONDUITE D'ASPIRATION 420 MM
10	8004424	REINIGERBEHÄLTER	DETERGENT CONTAINER	CONTENEUR DE DETERGENT
11	0113098	MAGNETVENTILFILTERSIEB	FILTER FOR SOLENOID VALVE	TAMIS-FILTRE D'ELECTROVANNE
12	8005393	ANSAUGROHR, 340 MM	SUCTION TUBE, 340 MM	CONDUITE D'ASPIRATION 340 MM
13	8003830	KLARSPÜLERBEHÄLTER	RINSE AID CONTAINER	CONTENEUR DE PRODUIT TENSIO-ACTIF
14	* 9538712	SCHLAUCH BLAU Ø6	HOSE BLUE Ø6	TUYAU BLEU Ø6
15	V 9505652	SCHLAUCH KLARSPÜLER KPL.	HOSE RINSE AID CPL.	TUYAU PRODUIT TENSIO ACTIF CPL.
16	9625978	KLARSPÜLDOSIERPUMPE KPL.	RINSE AID DOSING PUMP CPL.	POMPE DE DOSAGE TENSIO ACTIF CPL.
	0265021	TRICHTER	FUNNEL	ENTONNOIR

# 11.73 ELEKTRONIKSTEUERUNG

# 11.73 ELECTRONIC CONTROL

# 11.73 COMMAND DE ELECTRONIQUE

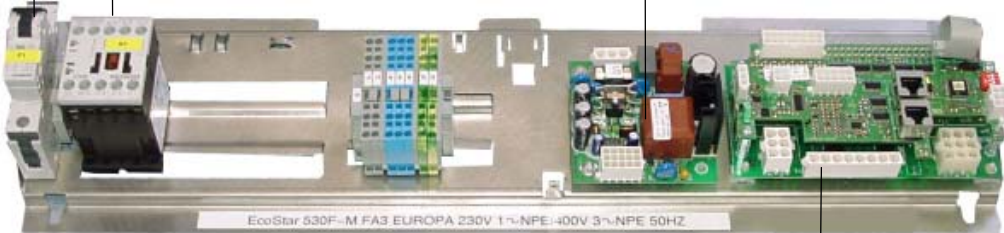
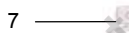

## 11.73 ELEKTRONIKSTEUERUNG

## 11.73 ELECTRONIC CONTROL

## 11.73 COMMAND DE ELECTRONIQUE



EL11\_73.doc  
21.03.2006/BP

POS	IDENT. NR. IDENT. NO.	BEZEICHNUNG	DESIGNATION	DESIGNATION
1	* 9619253	FOLIENASTATUR ECOSTAR 530F-M	SENSOR TOUCH PANEL ECOSTAR 530F-M	CLAVIER SENSITIF ECOSTAR 530F-M
2	9618914	FOLIENASTATUR ECOSTAR 530F-M EW	SENSOR TOUCH PANEL ECOSTAR 530F-M EW	CLAVIER SENSITIF ECOSTAR 530F-M EW
3	9617233	MONTAGESATZ ANZEIGENPLATINE	ASSEMBLY KIT SCALE CIRCUIT BOARD	KIT D'INSTALLATION UNITE CEN- TRALE PLATINE D'AFFICHAGE
4	9544752	ABDECKUNG	COVER	CHAPPE
5	* 9541525	MONTAGESATZ CPU	ASSEMBLY KIT CPU	KIT D'INSTALLATION UNITE CEN- TRALE
6	* 9605615	TEMPERATURFÜHLER TANK	TEMPERATURE PROBE TANK	SONDE DE TEMPERATURE BAC
7	9607101	KABELBINDERHALTER	CABLE TIE SUPPORT	SUPPOR D'ATTACHE-CABLE
8	* 0122106	HEBEL FÜR MIKROSCHALTER	LEVER FOR SENSITIVE SWITCH	LEVIER POUR MICRORUPTEUR
9	* 0122103	MIKROSCHALTER	SWITCH	INTERRUPTEUR
10	* 9617237	E/A2 PLATINE	E/A2 CIRCUIT BOARD	E/A2 PLATINE
11	* 9533502	NETZTEIL	POWER UNIT	BLOC DE ADIMENTATION
12	9547516	SCHÜTZ	CONTACTOR	CONTACTEUR
13	9612715	SICHERUNGSAUTOMAT	FUSE BLOCK	COUPE CIRCUIT AUTOMATIQUE
14	9617235	E/A1 PLATINE	E/A1 CIRCUIT BOARD	E/A1 PLATINE
	0145047	FEINSICHERUNG 2A	FINE WIRE FUSE 2A	FUSIBLE FIN 2A
	9611761	FEINSICHERUNG 16A	FINE WIRE FUSE 16A	FUSIBLE FIN 16A
	9621015	EPROM	EPROM	EPROM
	9622871	E-EPROM STANDARD	E-EPROM STANDARD	E-EPROM STANDARD
	9622870	E-EPROM EW 10	E-EPROM IS 10	E-EPROM AI 10
	9622869	E-EPROM FA3	E-EPROM FA3	E-EPROM FA3

## 13.48 BAUGRUPPEN / EINZELTEILE

## 13.48 COMPONENT BLOCKS / PARTS

## 13.48 BLOCS / PIECES DETACHEES



BE13\_48.doc  
21.03.2006/BP



POS	IDENT. NR. IDENT. NO.	BEZEICHUNG	DESIGNATION	DESIGNATION
1	9613827-03	SEITENVERKLEIDUNG LINKS	SIDE CLADDING, LEFT	REVETEMENT LATERAL GAUCHE
2	8005632	ABDECKUNG	COVER	RECOUVREMENT
	9534425	ABDECKUNG EW	COVER IS	RECOUVREMENT AI
3	9613809	TÜR KPL.	DOOR CPL.	PORTE CPL
4	9613827-04	SEITENVERKLEIDUNG RECHTS	SIDE CLADDING, RIGHT	REVETEMENT LATERAL DROIT
5	9613719	FRONTBLECH FÜR 2 VORRATS- BEHÄLTER	FRONT SHEET FOR 2 CONTAINER	TOLE FRONTALE POUR 2 RECI- PIENTS
	9624403	FRONTBLECH FÜR 1 VORRATS- BEHÄLTER	FRONT SHEET FOR 1 CONTAINER	TOLE FRONTALE POUR 1 RECI- PIENTS
	9624339	FRONTBLECH OHNE VORRATS- BEHÄLTER	FRONT SHEET WITHOUT CON- TAINER	TOLE FRONTALE SANS RECIPIENT
6	9613834	RÜCKWAND	CLADDING, BACK	REVETEMENT ARRIERE
	9622370	RÜCKWAND EW	CLADDING, BACK IS	REVETEMENT ARRIERE AI
	9617174	BODENBLECH	BOTTOM SHEET	TÔLE INSÉRIEUR
	9505089	ZULAUFSCHLAUCH	HOSE WATER SUPPLY	TUYAU DE RACCORDEMENT D'EAU
		<b>FÜR GROSSBRITANNIEN</b>	<b>FOR GREAT BRITAIN</b>	<b>POUR GRANDE-BRETAGNE</b>
	9500011	ZULAUFSCHLAUCH WRC-ZULASSUNG	HOSE WATER SUPPLY WRC APPROVAL	TUYAU DE RACCORDEMENT D'EAU APPROBATION WRC
	9505088	ABLAUFSCHLAUCH	DISCHARGE HOSE	TUYAU DE VIDANGE
	0460035	KUNSTSTOFF-FUSS	PLASTIC FOOT	PIED EN PLASTIC

## 18.22 LAUGENPUMPE

## 18.22 DRAIN PUMP

## 18.22 POMPE DE VIDANGE



LP18\_21.doc  
2006-02-10/BP

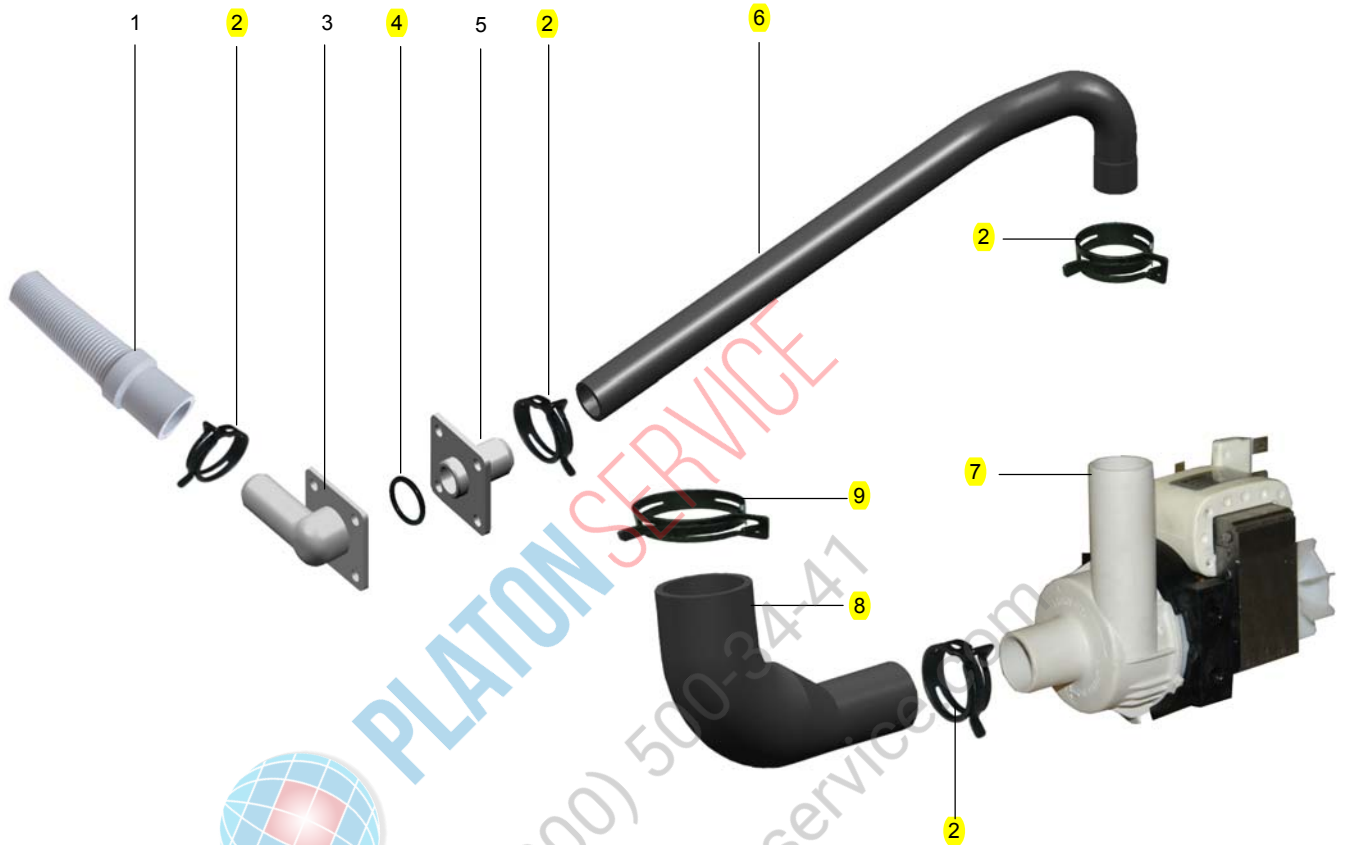

POS	IDENT. NR. IDENT. NO.	BEZEICHNUNG	DESIGNATION	DESIGNATION
1	9609672	ABLAUSCHLAUCH	DRAIN HOSE	TUYAU DE VIDANGE
2	9607417	FEDERBANDSCHELLE Ø30	HOSE CLAMP TAPE Ø30	RUBAN COLLIER DE SERRAGE Ø30
3	9503011	SCHLAUCHANSCHLUSS	HOSE CONNECTOR	RACCORD DE TUYAU
4	0401017	O-RING	O-RING	BAGUE
5	9502991	SCHLAUCHANSCHLUSS	HOSE CONNECTOR	RACCORD DE TUYAU
6	9623821	SCHLAUCH	HOSE	TUYAU
7	9624073	LAUGENPUMPE KPL. 200-240V / 50HZ / 0,07KW	DRAIN PUMP CPL. 200-240V / 50HZ / 0,07KW	POMPE DE VIDANGE CPL. 200-240V / 50HZ / 0,07KW
8	9625209	SCHLAUCHVERBINDUNG	HOSE COUPLING	RACCORD POUR TUYAUX
9	9624003	FEDERBANDSCHELLE Ø50	HOSE CLAMP TAPE Ø50	RUBAN COLLIER DE SERRAGE Ø50

## 22.27 DRUCKSTEIGERUNGSPUMPE

## 22.27 BOOSTER PUMP

## 22.27 SURPRESSEUR



## 22.27 DRUCKSTEIGERUNGSPUMPE

## 22.27 BOOSTER PUMP

## 22.27 SURPRESSEUR



DSP22\_27.doc  
2006-04-27/BP

POS	IDENT. NR. IDENT. NO.	BEZEICHNUNG	DESIGNATION	DESIGNATION
1	9607418	FEDERBANDSCHELLE Ø21	HOSE CLAMP TAPE Ø21	RUBAN COLLIER DE SERRAGE Ø21
2	9608600	SCHLAUCH ½"	HOSE ½"	TUYAU ½"
3	9601255	SCHLAUCHVERTEILER	DISTRIBUTION PIPE	DISTRIBUTION DE TUYAU
4	9607417	FEDERBANDSCHELLE Ø30	HOSE CLAMP TAPE Ø30	RUBAN COLLIER DE SERRAGE Ø30
5	9622355	SCHLAUCHVERBINDUNG	HOSE COUPLING	RACCORD POUR TUYAUX
6	* 9544228	DRUCKSTEIGERUNGSPUMPE 200-240V 0,2 KW 50 HZ	BOOSTER PUMP 200-240V 0,2 KW 50 HZ	SURPRESSEUR 200-240V 0,2 KW 50 HZ
	* 9523267	PUMPENLAUFRAD 50 HZ	PUMP WHEEL 50 HZ	ROUE DE POMPE 50 HZ
	* 9523844	GLEITRINGDICHTUNG KPL.	SLIDING SEAL CPL.	JOINT AXIAL CPL.
	* 9523260	O-RING	O-RING	BAGUE
6	* 0408238	FLACHDICHTUNG 17X24X2	FLAT PACKING 17X24X2	GARNITURE PLATE 17X24X2
7	* 9520030	KONDENSATOR	CONDENSER	CONDENSEUR



PLATON SERVICE  
8 (800) 500-34-41  
www.platonservice.com



## 24.07 FREIER AUSLAUF

## 24.07 AIR GAP

## 24.07 ECOULEMENT LIBRE



Fa24\_7.doc  
01.12.2002/FUS



POS	IDENT. NR. IDENT. NO.	BEZEICHNUNG	DESIGNATION	DESIGNATION
1	* 9523195	FREIER AUSLAUF KPL.	AIR GAP CPL.	ECOULEMENT LIBRE CPL.
2	* 0650076	DICHTUNG	PACKING	JOINT
3	0233036	SCHLAUCHKLEMME 10/16	HOSE WIRE CLAMP 10/16	COLLIER DE SERRAGE 10/16
4		SIEHE BLATT 04 MAGNETVENTIL	SEE PAGE 04 SOLENOID VALVE	VOIR PAGE 04 ELECTRO VANNE
5		SIEHE BLATT 10 DOSIERGERÄTE	SEE PAGE 10 DOSING UNITS	VOIR PAGE 10 DOSEURS
6	9605930	SCHLAUCHKLEMME 8,5-9,5	HOSE WIRE CLAMP 8,5-9,5	COLLIER DE SERRAGE 8,5-9,5
7		SIEHE BLATT 08 EINBAUBOILER	SEE PAGE 08 INCORPORATED BOILER	VOIR PAGE 08 SURCHAUFFEUR INCORPORE
8		SIEHE BLATT 08 EINBAUBOILER	SEE PAGE 08 INCORPORATED BOILER	VOIR PAGE 08 SURCHAUFFEUR INCORPORE
9	9607418	FEDERBANDSCHELLE Ø21	HOSE CLAMP TAPE Ø21	RUBAN COLLIER DE SERRAGE Ø21
10	9609462	FEDERBANDSCHELLE Ø17	HOSE CLAMP TAPE Ø17	RUBAN COLLIER DE SERRAGE Ø17
11	8000609	WASSERLEITBLECH	WATER GUIDING SHEET	TOLE DE DEVIATION D'EAU



## 25.02 TÜRGEWICHTSAUSGLEICH

## 25.02 DOOR COUNTERWEIGHT

## 25.02 EQUILIBRAGE DE POIDS DE PORTE

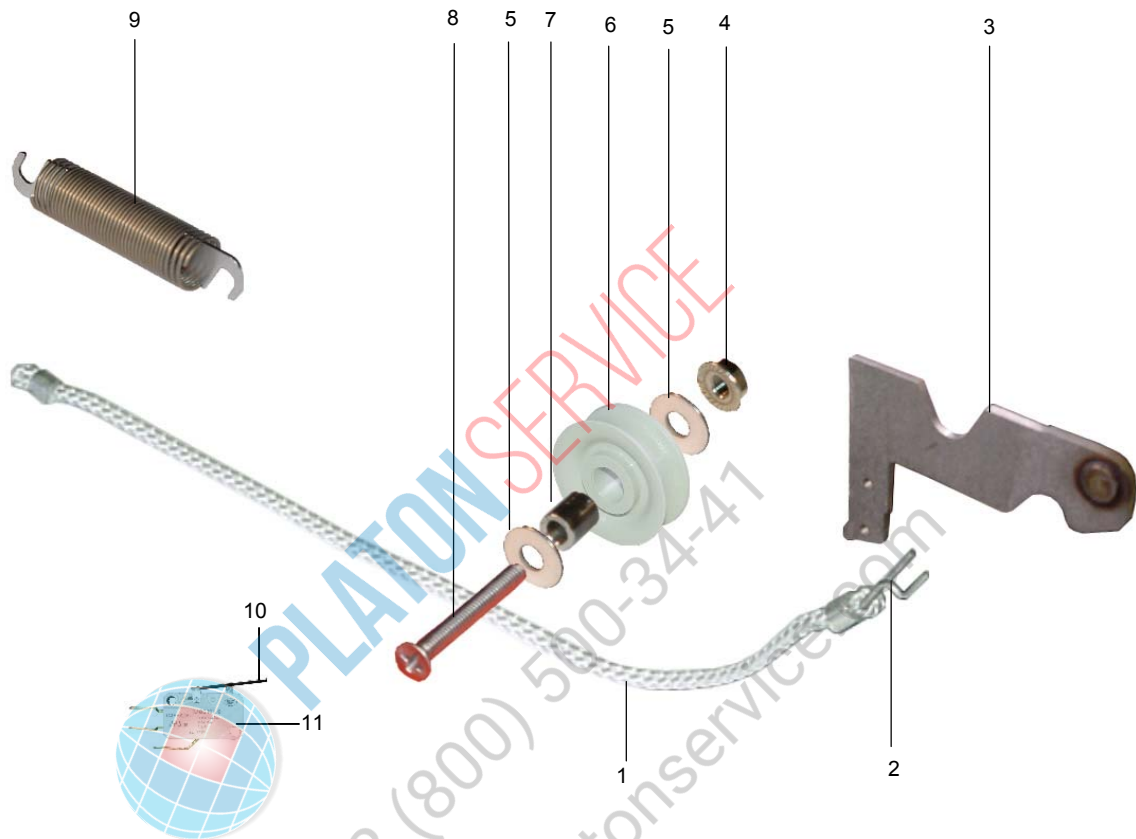

POS	IDENT. NR. IDENT. NO.	BEZEICHNUNG	DESIGNATION	DESIGNATION
1	V 0435151	SEIL	ROPE	CORDE
2	* 0435150	SEILHAKEN	ROPE HOOK	CROCHET
3	9613801-03	TÜRSCHARNIER LINKS KPL.	DOORHINGE LEFT CPL.	PORTE A CHARNIERE GAUCHE CPL.
3	9613801-04	TÜRSCHARNIER RECHTS KPL.	DOORHINGE RIGHT CPL.	PORTE A CHARNIERE DROIT CPL.
4	0337001	MUTTER M5	NUT M5	ECROU M5
5	0340020	SCHEIBE	DISK	DISQUE
6	* 9600964	SEILROLLE	ROPE ROLLER	ROULEAU POUR CORDE
7	9520736	LAGERRING	BEARING RING	BAGUE DE PALIER
8	0306121	SCHRAUBE M5X20	SCREW M5X20	VIS M5X20
9	* 9521764	ZUGFEDER KPL.	TENSION SPRING CPL.	RESSORT DE TENSION CPL.
10	0122106	HEBEL FÜR MIKROSCHALTER	LEVER FOR SENSITIVE SWITCH	LEVIER POUR MICRORUPTEUR
11	0122103	MIKROSCHALTER	SWITCH	INTERRUPTEUR

## Das Programm auf einen Blick

**1**

**Spülautomaten mit stationärem  
Waschverfahren**  
Geschirr- und Gläserpülautomaten;  
Topf- und Behälterspülautomaten;  
Salat- und Gemüsewaschautomaten

**2**

**Spülautomaten mit Durchlaufsystem**  
Geschirrspülautomaten mit Bandtransport-,  
Korbtransport- oder Umlaufsystem

**3**

**Speziälpülenanlagen**  
Vollautomatische Spülenanlagen für Geschirr,  
Tablets und Besteck; Flight-Catering-  
Anlagen; Industriespülautomaten; Trolley-,  
Behälter- und Transportwagenspülenanlagen

**4**

**Förderanlagen**  
Tablett- und Geschirrtransportbänder,  
Geschirrsortier- und Stapleinrichtungen

**5**

**Speisereste-Behandlungsanlagen**  
Maschinen und Anlagen zur Aufbereitung  
von Speiseresten für eine umweltgerechte  
Entsorgung

**6**

**Großkücheneinrichtungen**  
Geräte und Mobiliar für Relais- und Stations-  
küchen; Transportwagen; Tablett- und Teller-  
stapler; Tische, Schränke und Regale aus  
Edelstahl; diverse Organisationsmittel

**7**

**Sanitäreinrichtungen für Krankenhäuser  
und Heime**  
Reinigungs- und Desinfektionsautomaten  
für Steckbecken und andere Pflegegeschirre;  
Pflegekombinationen; Komplettausstattung  
für Unreine Arbeitsräume

## Our product range

**Automatic dishwashing machines  
with fixed washing system**

**Belt conveyor and rack transport  
machines**  
for continuous throughput operations

**Special purpose warewashing solutions**  
such as semi and fully automatic systems,  
designed for the catering industry in general

**Conveying systems**  
for vertical and horizontal transport of trays  
and dishes

**Food waste treatment systems**  
Water conditioning appliances

**Central wash-up equipment**  
Tables, cabinets, tray and plate stackers

**Sanitary appliances for healthcare  
establishments**  
Automatic cleaning and disinfection  
appliances for bedpans and other care  
utensils

## Notre gamme de production

**Lave-vaisselle à procéder de lavage  
stationnaire**  
Automates de lavage

**Lave-vaisselle automatiques à passage  
continu**  
Lave-vaisselle automatiques à convoyeur et  
à transport de paniers

**Lave-vaisselle spéciaux**  
Installations de lavage entièrement  
automatiques et semi-automatiques,  
lave-vaisselle industriels

**Installations de transport**  
pour le transport vertical et horizontal de  
plateaux

**Installations de traitement de déchets  
alimentaires**  
ainsi que des installations de traitement  
d'eau

**Installations pour grandes cuisines**  
Tables, empileurs de plateaux et d'assiettes

**Installations sanitaires pour hôpitaux et  
maisons de soins**  
Automates de nettoyage et de désinfection,  
combinés de soins



MEIKO Maschinenbau GmbH & Co. KG  
Englerstr. 3 · 77652 Offenburg · Germany  
Tel. + 49 (0)781/203-0  
Fax +49 (0)781/203-1274  
e-mail: info@meiko.de · www.meiko.de